

SHANGHAI

DESIGN GIUSEPPE MANZONI
2015



Programma completo di elementi componibili, composto da elementi di seduta, schienali imbottiti, cuscini di schienale e strutture di supporto in ferro e/o rivestite in cuoio da mixare e combinare tra loro. Sedute con struttura in legno, disponibili nelle profondità 100 cm e 120 cm, rivestite in poliuretano espanso D21 con trapuntino superiore in piuma d'oca. Schienale imbottito portante: base in legno e poliuretano espanso D35, con supporto antiscivolo. Cuscino schienale: piuma d'oca. Cuscino bracciolo: poliuretano espanso D21 con anima portante in lamiera di ferro mm 4. Schienale: lamiera di ferro mm 4 verniciata bianca/nera/grigio antracite opaco. Completano la collezione la libreria ed il server.

Upholstery program of modular units consisting of single seat elements, back cushions and free-standing iron back support which are available in leather cover too. Seat with wooden structure available in cm 100 and cm 120 depth, padded Kg21/m³ polyurethane foam and an upper quilt. Back in anti-slip D35 polyurethane foam. Back cushion in goose feather. Armrest cushion: Kg21/m³ polyurethane foam with mm 4 iron metal core Iron back support, mm 4 available in white / black / dark grey lacquer or in hard-leather cover. Accessories are a side small library and and a metal C-shaped stand.walnut or wenge stain.

SHANGHAI
DESIGN GIUSEPPE MANZONI
2015

**SCHIENALE FERRO + CUSCINO SCHIENALE
IRON BACKREST ELEMENT + BACK CUSHION**



**SCHIENALE PORTANTE
SELF STANDING BACKREST**



SHANGHAI
 DESIGN GIUSEPPE MANZONI
 2015

SH0000
 element 100 x 100

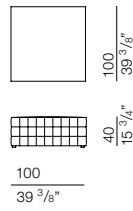

SH0001
 element 100 x 130

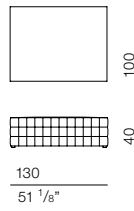

SH0018
 element 100 x 150

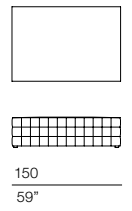

SH0002
 element 170

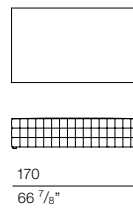

SH0003
 element 190

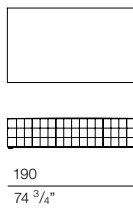

SH0004
 element 210

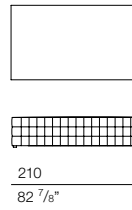

SH0005
 element 230

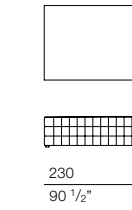

SH0006
 element 250

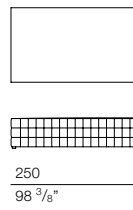

SH0007
 element 280

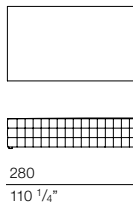

SH0020
 element 120 x 120

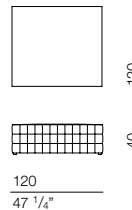

SH0021
 element 150 x 120

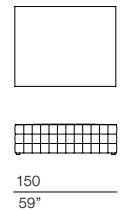

SH0022
 element 170 x 120

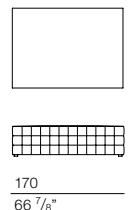

SH0023
 element 190 x 120

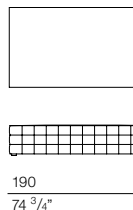

SH0024
 element 210 x 120

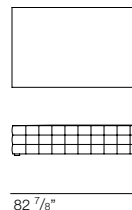

SH0025
 element 230 x 120

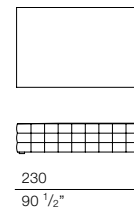

SH0026
 element 250 x 120

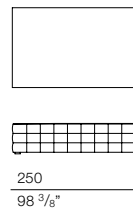

SH0027
 element 280 x 120

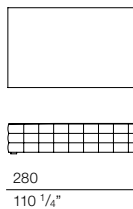

SH0033
 element Ø 130

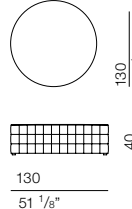

SHANGHAI
DESIGN GIUSEPPE MANZONI
2015



SH0008
back cushion

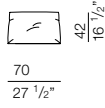

SH0009
back cushion

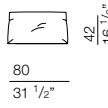

SH0010
back cushion

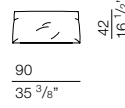

SH0011
two back cushions slim

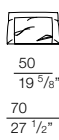

SH0012
two back cushions slim

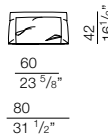

SH0013
two back cushions slim

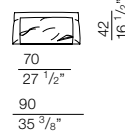

SH0014
iron backrest element

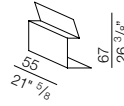

SH0015
server

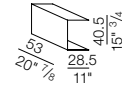

SH0016
mini library

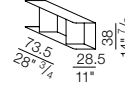

SH0017
arm cushion

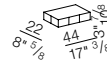

SH0028
self standing backrest 70 cm

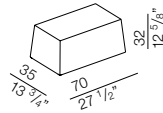

SH0029
self standing backrest 80 cm

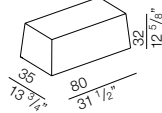

SH0030
self standing backrest 90 cm

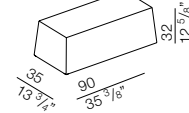

SH0031
cushion 60 cm for self standing backrest

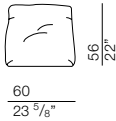

SH0032
cushion 70 cm for self standing backrest

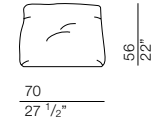

SHANGHAI

DESIGN GIUSEPPE MANZONI
2015

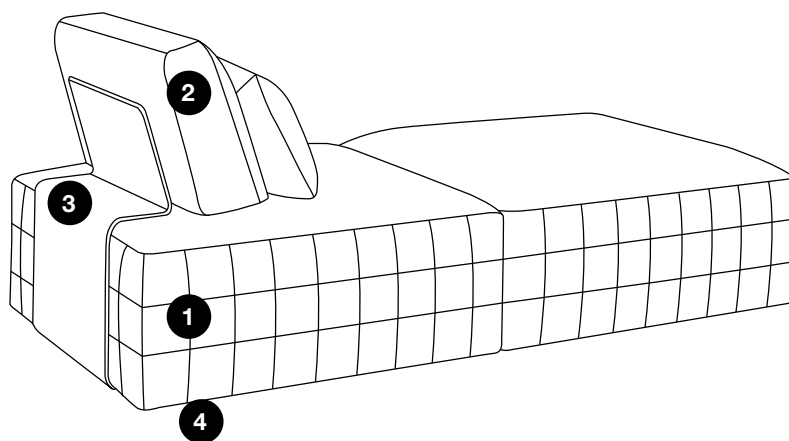

MATERIALI IMPIEGATI

1 STRUTTURA
Legno rivestita in poliuretano espanso D21
e piuma d'oca
2 CUSCINO SCHIENALE
Piuma d'oca
3 SCHIENALE
Ferro finitura Bianco opaco
Ferro finitura Nero opaco
Ferro finitura Antracite opaco
Ferro rivestito in Cuoio

FINITURE

4 PIEDINI
Plastica nera

USED MATERIALS

1 STRUCTURE
Wood covered in D21polyurethane foam
and Feather
2 BACKRESTS
Feather
3 BACK SUPPORT
Iron White lacquer
Iron Black lacquer
Iron Dark Grey lacquer
Hard-leather cove

FINISHES

4 FEET
Plastic feet

MANUTENZIONE ORDINARIA DI UN DIVANO RIVESTITO IN TESSUTO

- I rivestimenti possono presentare variazioni di tonalità da una partita all'altra.
- Evitare l'esposizione del prodotto alla luce solare diretta, soprattutto se questa è filtrata da vetrata.
- Tutti i rivestimenti sfoderabili richiedono periodicamente il ripristino delle tensioni iniziali regolando le parti velcrate.
- Per i rivestimenti sfoderabili, attenersi scrupolosamente alle modalità di lavaggio riportate sul cartoncino posto sul prodotto.

MANUTENZIONE ORDINARIA DI UN DIVANO RIVESTITO IN PELLE

- Evitare l'esposizione del prodotto alla luce solare diretta, soprattutto se questa è filtrata da vetrata.
- Evitare di posizionare il prodotto in prossimità di fonti di calore dirette quali camini, stufe, termosifoni.
- Per liberare i pori della pelle dalla polvere che si deposita, utilizzare un panno umido ben strizzato da usare con delicatezza. Ciò vale soprattutto per le tipologie "Naturale", che non sono trattate con alcun prodotto coprente, pertanto sono più delicate.
- Per la pulizia ordinaria delle pelli tipo "Extra" e Scozia" si può ricorrere a prodotti specifici in commercio, seguendo le istruzioni date dal produttore.
- In caso di macchie accidentali suggeriamo di tamponare immediatamente con carta assorbente sempre evitando di strofinare, ma limitandosi ad asciugare il liquido. La buona riuscita dell'operazione dipende in gran parte dalla tempestività dell'intervento oltre che dall'origine della macchia.
- Non usare mai alcool o solventi, che danneggerebbero definitivamente i rivestimenti.

MANUTENZIONE ORDINARIA DEI CUSCINI IN PIUMA

- Regola fondamentale è quella di sprimacciare in modo da ridare il volume originale. Non usare aspirapolvere o battipanni. Arieggiare di tanto in tanto.

ROUTINE MAINTENANCE OF A SOFA WITH FABRIC COVERS

- The covers may vary in nuances from one batch to another.
- Avoid exposing the product to direct sunlight, particularly if it is filtered through glass.
- All removable covers regularly require the initial tautness to be restored, adjusting the parts with velcro.
- For all removable covers, please follow the washing instructions on the tag stitched on the product.

ROUTINE MAINTENANCE OF A SOFA UPHOLSTERED IN LEATHER

- Avoid exposing the product to direct sunlight, particularly if it is filtered through glass.
- Do not position the product near sources of direct heat such as fireplaces, stoves or radiators.
- To free the pores of the leather from the dust that has collected, use with care a wet cloth that has been wrung out. This applies above all to the "Naturale" types which are not treated and therefore more delicate.
- For routine cleaning of the "Extra" and "Scozia" leather use can be made of specific products available on the market, following the manufacturer's instructions.
- In the event of accidental staining we recommend blotting the stain immediately with absorbent paper, never rubbing but instead only drying the liquid. The success of the operation mostly depends on prompt action and the origin of the stain.
- Never use alcohol or solvents which alter permanently the upholstery.

ROUTINE MAINTENANCE OF THE FEATHER CUSHIONS

- The basic rule is to fluff up the cushions to restore the original volume. Do not use vacuum cleaners or carpet beater. Airing from time to time.